

ACES DUST CONTROL

Separator type JK-PS

Type JK-PS separators are designed to separate solids from carrier air in over- or under-pressure systems.

The separator design ensures low pressure loss and unpressurised material separation, making it possible to install the separator directly connected to other equipment, such as compressors and containers.

They are able to separate particles greater than 3 mm, but the max. size is governed by the dimensions of the rotor chamber.

Rotor blades are fitted with vulkolan rubber blades to ensure a seal between rotor and rotor housing.

Operating temperature max. +60°C and min. -10°C

Rotor RPM = 18 min⁻¹

The capacities stated are valves from tests with mixed cardboard, paper and corrugated cardboard weighing 40 kg/m³.

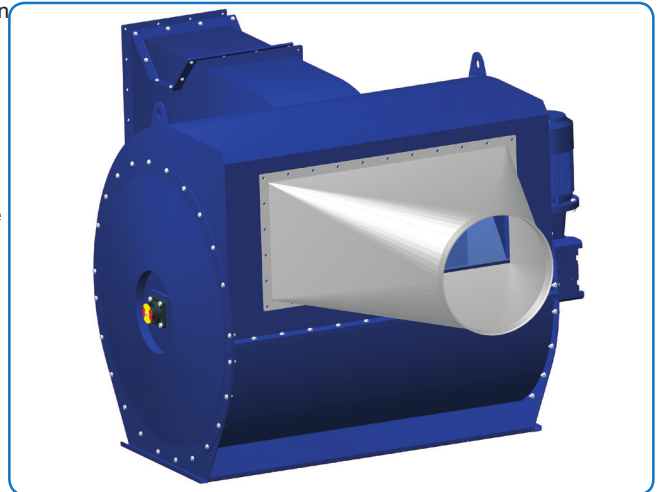

Type	Capacity m ³ /h	Capacity kg/h	Dimensions		kW	Ampere consumption at 400 V	Weight kg
			min ⁻¹	Max. pressure mmVS			
JK-5PS	5000	700	16	800	1.5	3.35	242
JK-10PS	10000	1200	16	800	2.2	4.55	410
JK-20PS	20000	2500	17	650	4.0	8.40	814

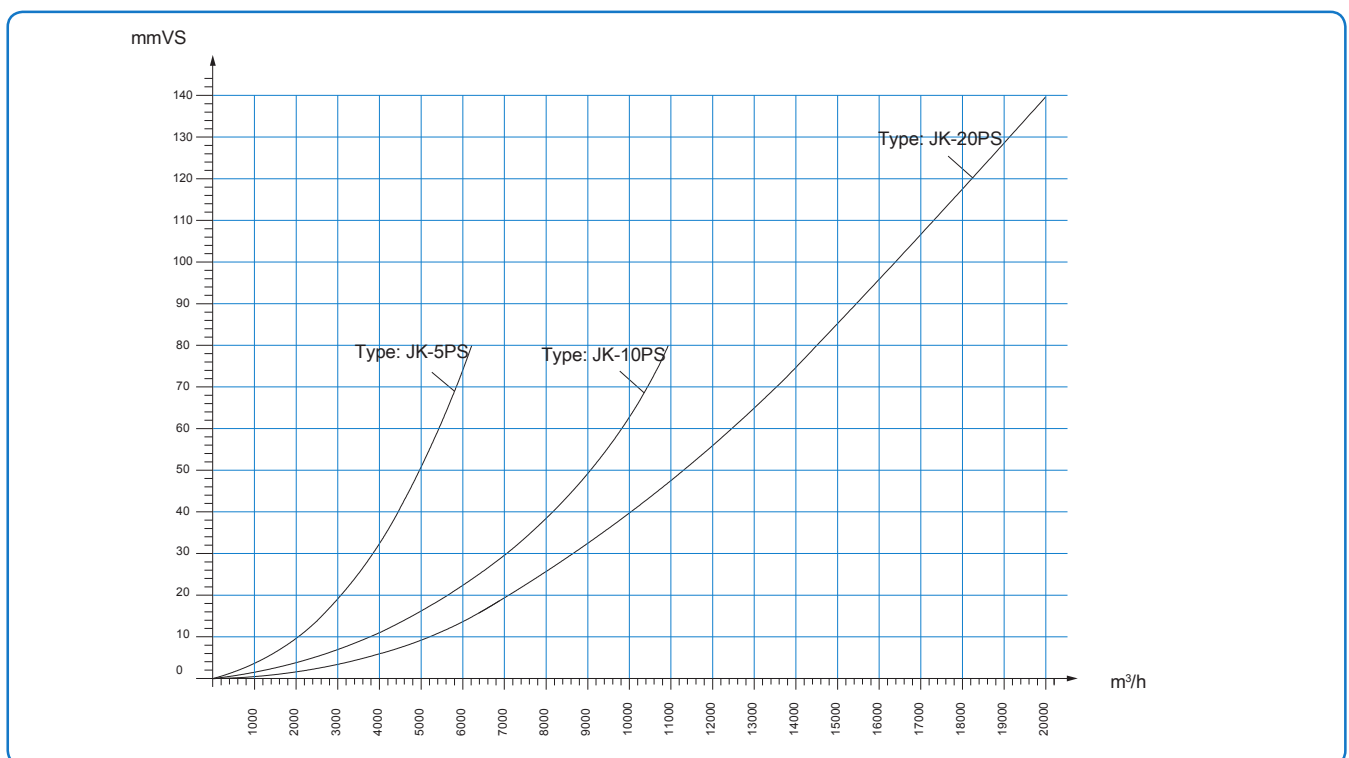

Pressure loss curves depend on air volume.

ACES DUST CONTROL

Separator

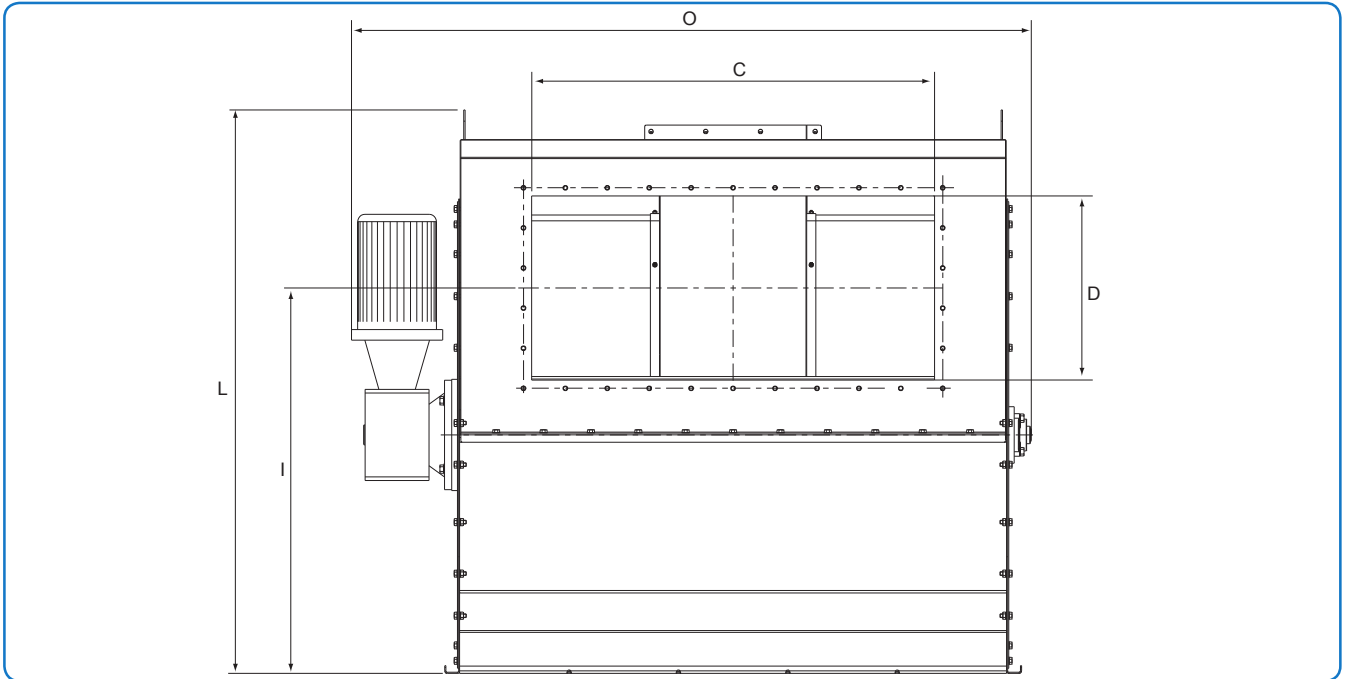

Dimensional specifications for lengths are given in the table below.

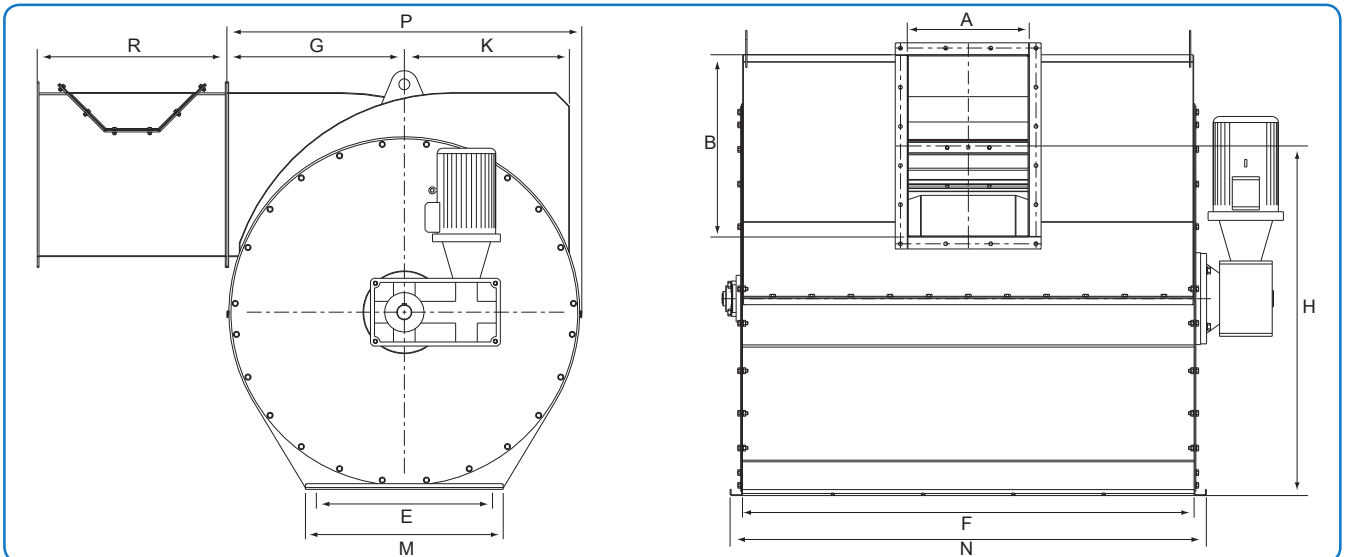

Dimensional specifications for lengths are given in the table below.

Type	Dimensions															
	A mm	B mm	C mm	D mm	E mm	F mm	G mm	H mm	I mm	K mm	L mm	M mm	N mm	O mm	P mm	R mm
JK-5PS	220	320	600	300	500	750	351	665	630	311	875	586	836	1072	712	500
JK-10PS	220	500	750	400	500	1000	457	814	809	411	1120	580	1082	1372	914	600
JK-20PS	400	600	1100	500	650	1500	655	1162	1057	609	1544	730	1582	1884	1310	700